

CHAPTER 7

SYMMETRICAL COMPONENTS AND REPRESENTATION OF FAULTED NETWORKS

An unbalanced three-phase system can be resolved into three balanced systems in the sinusoidal steady state. This method of resolving an unbalanced system into three balanced phasor system has been proposed by C. L. Fortescue. This method is called *resolving symmetrical components of the original phasors* or simply *symmetrical components*. In this chapter we shall discuss symmetrical components transformation and then will present how unbalanced components like Y- or Δ -connected loads, transformers, generators and transmission lines can be resolved into symmetrical components. We can then combine all these components together to form what are called *sequence networks*.

7.1 SYMMETRICAL COMPONENTS

A system of three unbalanced phasors can be resolved in the following three symmetrical components:

- Positive Sequence: A balanced three-phase system with the same phase sequence as the original sequence.
- Negative sequence: A balanced three-phase system with the opposite phase sequence as the original sequence.
- Zero Sequence: Three phasors that are equal in magnitude and phase.

Fig. 7.1 depicts a set of three unbalanced phasors that are resolved into the three sequence components mentioned above. In this the original set of three phasors are denoted by V_a , V_b and V_c , while their positive, negative and zero sequence components are denoted by the subscripts 1, 2 and 0 respectively. This implies that the positive, negative and zero sequence components of phase-a are denoted by V_{a1} , V_{a2} and V_{a0} respectively. Note that just like the voltage phasors given in Fig. 7.1 we can also resolve three unbalanced current phasors into three symmetrical components.

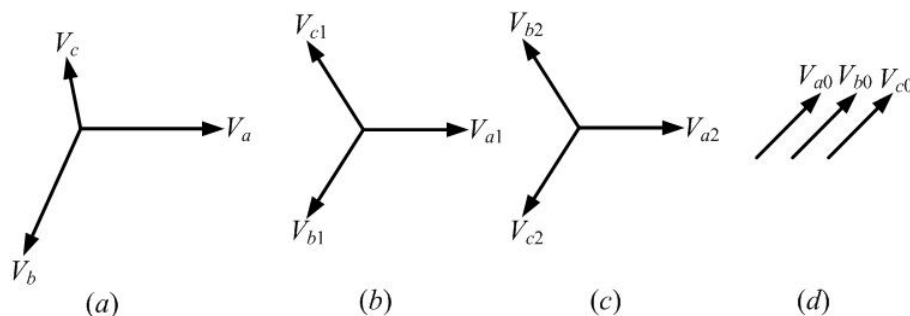

Fig. 7.1 Representation of (a) an unbalanced network, its (b) positive sequence, (c) negative sequence and (d) zero sequence.

7.1.1 Symmetrical Component Transformation

Before we discuss the symmetrical component transformation, let us first define the a -operator. This has been given in (1.34) and is reproduced below.

$$a = e^{j120^\circ} = -\frac{1}{2} + j\frac{\sqrt{3}}{2} \quad (7.1)$$

Note that for the above operator the following relations hold

$$\begin{aligned} a^2 &= e^{j240^\circ} = -\frac{1}{2} - j\frac{\sqrt{3}}{2} = a^* \\ a^3 &= e^{j360^\circ} = 1 \\ a^4 &= e^{j480^\circ} = e^{j360^\circ} e^{j120^\circ} = a \\ a^5 &= e^{j600^\circ} = e^{j360^\circ} e^{j240^\circ} = a^2 \text{ and so on} \end{aligned} \quad (7.2)$$

Also note that we have

$$1 + a + a^2 = 1 - \frac{1}{2} + j\frac{\sqrt{3}}{2} - \frac{1}{2} - j\frac{\sqrt{3}}{2} = 0 \quad (7.3)$$

Using the a -operator we can write from Fig. 7.1 (b)

$$V_{b1} = a^2 V_{a1} \text{ and } V_{c1} = a V_{a1} \quad (7.4)$$

Similarly from Fig. 7.1 (c) we get

$$V_{b2} = a V_{a2} \text{ and } V_{c2} = a^2 V_{a2} \quad (7.5)$$

Finally from Fig. 7.1 (d) we get

$$V_{a0} = V_{b0} = V_{c0} \quad (7.6)$$

The symmetrical component transformation matrix is then given by

$$\begin{bmatrix} V_{a0} \\ V_{a1} \\ V_{a2} \end{bmatrix} = \frac{1}{3} \begin{bmatrix} 1 & 1 & 1 \\ 1 & a & a^2 \\ 1 & a^2 & a \end{bmatrix} \begin{bmatrix} V_a \\ V_b \\ V_c \end{bmatrix} \quad (7.7)$$

Defining the vectors V_{a012} and V_{abc} as

$$V_{a012} = \begin{bmatrix} V_{a0} \\ V_{a1} \\ V_{a2} \end{bmatrix}, \quad V_{abc} = \begin{bmatrix} V_a \\ V_b \\ V_c \end{bmatrix}$$

we can write (7.4) as

$$V_{a012} = CV_{abc} \quad (7.8)$$

where C is the symmetrical component transformation matrix and is given by

$$C = \frac{1}{3} \begin{bmatrix} 1 & 1 & 1 \\ 1 & a & a^2 \\ 1 & a^2 & a \end{bmatrix} \quad (7.9)$$

The original phasor components can also be obtained from the inverse symmetrical component transformation, i.e.,

$$V_{abc} = C^{-1}V_{a012} \quad (7.10)$$

Inverting the matrix C given in (7.9) and combining with (7.10) we get

$$\begin{bmatrix} V_a \\ V_b \\ V_c \end{bmatrix} = \begin{bmatrix} 1 & 1 & 1 \\ 1 & a^2 & a \\ 1 & a & a^2 \end{bmatrix} \begin{bmatrix} V_{a0} \\ V_{a1} \\ V_{a2} \end{bmatrix} = C^{-1} \begin{bmatrix} V_{a0} \\ V_{a1} \\ V_{a2} \end{bmatrix} \quad (7.11)$$

From (7.11) we can write

$$V_a = V_{a0} + V_{a1} + V_{a2} \quad (7.12)$$

$$V_b = V_{a0} + a^2V_{a1} + aV_{a2} = V_{b0} + V_{b1} + V_{b2} \quad (7.13)$$

$$V_c = V_{a0} + aV_{a1} + a^2V_{a2} = V_{c0} + V_{c1} + V_{c2} \quad (7.14)$$

Finally, if we define a set of unbalanced current phasors as I_{abc} and their symmetrical components as I_{a012} , we can then define

$$I_{a012} = CI_{abc} \quad (7.15)$$

$$I_{abc} = C^{-1}I_{a012}$$

Example 7.1: Let us consider a set of balanced voltages given in per unit by

$$V_a = 1.0, V_b = 1.0 \angle -120^\circ \text{ and } V_c = 1.0 \angle 120^\circ$$

These imply

$$V_b = a^2 \text{ and } V_c = a$$

Then from (7.7) we get

$$V_{a0} = \frac{1}{3}(1 + a^2 + a) = 0$$

$$V_{a1} = \frac{1}{3}(1 + a^3 + a^3) = 1.0 \text{ pu}$$

$$V_{a2} = \frac{1}{3}(1 + a^4 + a^2) = 0$$

We then see that for a balanced system the zero and negative sequence voltages are zero. Also the positive sequence voltage is the same as the original system, i.e.,

$$V_{a1} = V_a, V_{b1} = V_b \text{ and } V_{c1} = V_c$$

△△△

Example 7.2: All the quantities given in this example are in per unit. Let us now consider the following set of three unbalanced voltages

$$V_a = 1.0, V_b = 1.2 \angle -110^\circ \text{ and } V_c = 0.9 \angle 120^\circ$$

If we resolve them using (7.4) we then have

$$\begin{bmatrix} V_{a0} \\ V_{a1} \\ V_{a2} \end{bmatrix} = \frac{1}{3} \begin{bmatrix} 1 & 1 & 1 \\ 1 & a & a^2 \\ 1 & a^2 & a \end{bmatrix} \begin{bmatrix} 1.0 \\ 1.2 \angle -110^\circ \\ 0.9 \angle 120^\circ \end{bmatrix} = \begin{bmatrix} 0.0465 + j0.1161 \\ 1.0273 + j0.0695 \\ -0.0738 + j0.0466 \end{bmatrix} = \begin{bmatrix} 0.1250 \angle -68.16^\circ \\ 1.0296 \angle 3.87^\circ \\ 0.0873 \angle 147.72^\circ \end{bmatrix}$$

Therefore we have

$$V_{a0} = V_{b0} = V_{c0} = 0.125 \angle -68.16^\circ$$

$$V_{b1} = 1.0296 \angle -116.13^\circ, V_{c1} = 1.0296 \angle 123.87^\circ$$

$$V_{b2} = 0.0873 \angle 267.72^\circ, V_{c2} = 0.0973 \angle 27.72^\circ$$

Furthermore note that

$$V_a = V_{a0} + V_{a1} + V_{a2} = 1.0$$

$$V_b = V_{b0} + V_{b1} + V_{b2} = 1.2 \angle -110^\circ$$

$$V_c = V_{c0} + V_{c1} + V_{c2} = 0.9 \angle 120^\circ$$

△△△

7.1.2 Real and Reactive Power

The three-phase power in the original unbalanced system is given by

$$P_{abc} + jQ_{abc} = V_a I_a^* + V_b I_b^* + V_c I_c^* = V_{abc}^T I_{abc}^* \quad (7.16)$$

where I^* is the complex conjugate of the vector I . Now from (7.10) and (7.15) we get

$$P_{abc} + jQ_{abc} = V_{a012}^T C^{-T} C^{-1*} I_{a012}^* \quad (7.17)$$

From (7.11) we get

$$C^{-T}C^{-1*} = 3 \begin{bmatrix} 1 & 0 & 0 \\ 0 & 1 & 0 \\ 0 & 0 & 1 \end{bmatrix}$$

Therefore from (7.17) we get

$$P_{abc} + jQ_{abc} = 3(V_{a0}I_{a0}^* + V_{a1}I_{a1}^* + V_{a2}I_{a2}^*) \quad (7.18)$$

We then find that the complex power is three times the summation of the complex power of the three phase sequences.

Example 7.3: Let us consider the voltages given in Example 7.2. Let us further assume that these voltages are line-to-neutral voltages and they supply a balanced Y-connected load whose per phase impedance is $Z_Y = 0.2 + j0.8$ per unit. Then the per unit currents in the three phases are

$$I_a = \frac{V_a}{Z_Y} = 1.2127 \angle -75.96^\circ \text{ pu}$$

$$I_b = \frac{V_b}{Z_Y} = 1.4552 \angle 174.04^\circ \text{ pu}$$

$$I_c = \frac{V_c}{Z_Y} = 1.0914 \angle 44.04^\circ \text{ pu}$$

Then the real and reactive power consumed by the load is given by

$$P_{abc} = (1.0 \times 1.2127 + 1.2 \times 1.4552 + 0.9 \times 1.0914) \times \cos(75.96^\circ)$$

$$= 0.9559 \text{ pu}$$

$$Q_{abc} = (1.0 \times 1.2127 + 1.2 \times 1.4552 + 0.9 \times 1.0914) \times \sin(75.96^\circ)$$

$$= 3.8235 \text{ pu}$$

Now using the transformation (7.15) we get

$$\begin{bmatrix} I_{a0} \\ I_{a1} \\ I_{a2} \end{bmatrix} = \begin{bmatrix} -0.1229 - j0.0889 \\ 0.3839 - j1.1881 \\ 0.0331 + j0.1005 \end{bmatrix} = \begin{bmatrix} 0.1516 \angle -144.12^\circ \\ 1.2486 \angle -72.10^\circ \\ 0.1058 \angle 71.75^\circ \end{bmatrix} \text{ pu}$$

From the results given in Example 7.2 and from the above values we can compute the zero sequence complex power as

$$P_0 + jQ_0 = 3V_{a0}I_{a0}^* = 0.0138 + j0.0552 \text{ pu}$$

The positive sequence complex power is

$$P_1 + jQ_1 = 3V_{a1}I_{a1}^* = 0.9354 + j3.7415 \text{ pu}$$

Finally the negative sequence complex power is

$$P_2 + jQ_2 = 3V_{a2}I_{a2}^* = 0.0067 + j0.0269 \text{ pu}$$

Adding the three complex powers together we get the total complex power consumed by the load as

$$P_{abc} + jQ_{abc} = (P_0 + P_1 + P_2) + j(Q_0 + Q_1 + Q_2) = 0.9559 + j3.8235 \text{ pu}$$

△△△

7.1.3 Orthogonal Transformation

Instead of the transformation matrix given in (7.9), let us instead use the transformation matrix

$$C = \frac{1}{\sqrt{3}} \begin{bmatrix} 1 & 1 & 1 \\ 1 & a & a^2 \\ 1 & a^2 & a \end{bmatrix} \quad (7.19)$$

We then have

$$C^{-1} = \frac{1}{\sqrt{3}} \begin{bmatrix} 1 & 1 & 1 \\ 1 & a^2 & a \\ 1 & a & a^2 \end{bmatrix} \quad (7.20)$$

Note from (7.19) and (7.20) that $C^{-1} = (C^T)^*$. We can therefore state $C(C^T)^* = I_3$, where I_3 is (3×3) identity matrix. Therefore the transformation matrices given in (7.19) and (7.20) are orthogonal. Now since

$$C^{-T}C^{-1*} = (C^T)^*C = \begin{bmatrix} 1 & 0 & 0 \\ 0 & 1 & 0 \\ 0 & 0 & 1 \end{bmatrix}$$

we can write from (7.17)

$$P_{abc} + jQ_{abc} = V_{a0}I_{a0}^* + V_{a1}I_{a1}^* + V_{a2}I_{a2}^* \quad (7.21)$$

We shall now discuss how different elements of a power system are represented in terms of their sequence components. In fact we shall show that each element is represented by three equivalent circuits, one for each symmetrical component sequence.

7.2 SEQUENCE CIRCUITS FOR LOADS

In this section we shall construct sequence circuits for both Y and Δ -connected loads separately.

7.2.1 Sequence Circuit for a Y-Connected Load

Consider the balanced Y-connected load that is shown in Fig. 7.2. The neutral point (n) of the windings are grounded through an impedance Z_n . The load in each phase is denoted by Z_Y . Let us consider phase-a of the load. The voltage between line and ground is denoted by V_a , the line-to-neutral voltage is denoted by V_{an} and voltage between the neutral and ground is denoted by V_n . The neutral current is then

$$\begin{aligned} I_n &= I_a + I_b + I_c \\ &= 3I_{a0} + (I_{a1} + I_{b1} + I_{c1}) + (I_{a2} + I_{b2} + I_{c2}) = 3I_{a0} \end{aligned} \quad (7.22)$$

Therefore there will not be any positive or negative sequence current flowing out of the neutral point.

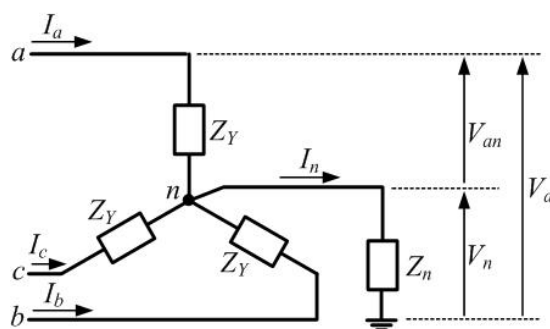

Fig. 7.2 Schematic diagram of a balanced Y-connected load.

The voltage drop between the neutral and ground is

$$V_n = 3Z_n I_{a0} \quad (7.23)$$

Now

$$V_a = V_{an} + V_n = V_{an} + 3Z_n I_{a0} \quad (7.24)$$

We can write similar expression for the other two phases. We can therefore write

$$\begin{bmatrix} V_a \\ V_b \\ V_c \end{bmatrix} = \begin{bmatrix} V_{an} \\ V_{bn} \\ V_{cn} \end{bmatrix} + \begin{bmatrix} V_n \\ V_n \\ V_n \end{bmatrix} = Z_Y \begin{bmatrix} I_a \\ I_b \\ I_c \end{bmatrix} + 3Z_n I_{a0} \begin{bmatrix} 1 \\ 1 \\ 1 \end{bmatrix} \quad (7.25)$$

Pre-multiplying both sides of the above equation by the matrix C and using (7.8) we get

$$V_{a012} = Z_Y I_{a012} + 3Z_n I_{a0} C \begin{bmatrix} 1 \\ 1 \\ 1 \end{bmatrix} \quad (7.26)$$

Now since

$$C \begin{bmatrix} 1 \\ 1 \\ 1 \end{bmatrix} = \begin{bmatrix} 1 \\ 0 \\ 0 \end{bmatrix}$$

We get from (7.26)

$$\begin{bmatrix} V_{a0} \\ V_{a1} \\ V_{a2} \end{bmatrix} = Z_Y \begin{bmatrix} I_{a0} \\ I_{a1} \\ I_{a2} \end{bmatrix} + 3Z_n \begin{bmatrix} I_{a0} \\ 0 \\ 0 \end{bmatrix} \quad (7.27)$$

We then find that the zero, positive and negative sequence voltages only depend on their respective sequence component currents. The sequence component equivalent circuits are shown in Fig. 7.3. While the positive and negative sequence impedances are both equal to Z_Y , the zero sequence impedance is equal to

$$Z_0 = Z_Y + 3Z_n \quad (7.28)$$

If the neutral is grounded directly (i.e., $Z_n = 0$), then $Z_0 = Z_Y$. On the other hand, if the neutral is kept floating (i.e., $Z_n = \infty$), then there will not be any zero sequence current flowing in the circuit at all.

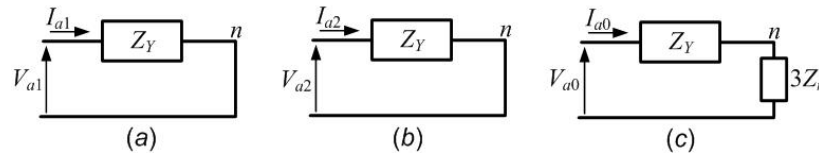

Fig. 7.3 Sequence circuits of Y-connected load: (a) positive, (b) negative and (c) zero sequence.

7.2.2 Sequence Circuit for a Δ -Connected Load

Consider the balanced Δ -connected load shown in Fig. 7.4 in which the load in each phase is denoted by Z_Δ . The line-to-line voltages are given by

$$\begin{aligned} V_{ab} &= Z_\Delta I_{ab} \\ V_{bc} &= Z_\Delta I_{bc} \\ V_{ca} &= Z_\Delta I_{ca} \end{aligned} \quad (7.29)$$

Adding these three voltages we get

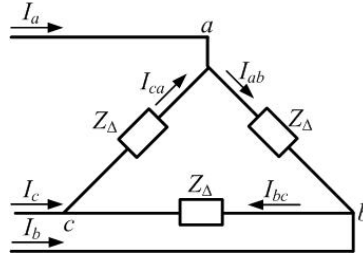

Fig. 7.4 Schematic diagram of a balanced Δ -connected load.

$$V_{ab} + V_{bc} + V_{ca} = Z_{\Delta}(I_{ab} + I_{bc} + I_{ca}) \quad (7.30)$$

Denoting the zero sequence component V_{ab} , V_{bc} and V_{ca} as V_{ab0} and that of I_{ab} , I_{bc} and I_{ca} as I_{ab0} we can rewrite (7.30) as

$$V_{ab0} = Z_{\Delta}I_{ab0} \quad (7.31)$$

Again since

$$V_{ab} + V_{bc} + V_{ca} = V_a - V_b + V_b - V_c + V_c - V_a = 0$$

we find from (7.31) $V_{ab0} = I_{ab0} = 0$. Hence a Δ -connected load with no mutual coupling has not any zero sequence circulating current. Note that the positive and negative sequence impedance for this load will be equal to Z_{Δ} .

Example 7.4: Consider the circuit shown in Fig. 7.5 in which a Δ -connected load is connected in parallel with a Y-connected load. The neutral point of the Y-connected load is grounded through an impedance. Applying Kirchoff's current law at the point P in the circuit we get

$$\begin{aligned} I_a &= \frac{V_a - V_b}{Z_{\Delta}} + \frac{V_a - V_c}{Z_{\Delta}} + \frac{V_a - V_n}{Z_Y} \\ &= \left(\frac{2}{Z_{\Delta}} + \frac{1}{Z_Y} \right) V_a - \frac{1}{Z_{\Delta}} (V_b + V_c) - \frac{V_n}{Z_Y} \end{aligned}$$

The above expression can be written in terms of the vector V_{abc} as

$$I_a = \left(\frac{3}{Z_{\Delta}} + \frac{1}{Z_Y} \right) V_a - \frac{1}{Z_{\Delta}} [1 \quad 1 \quad 1] V_{abc} - \frac{V_n}{Z_Y}$$

Since the load is balanced we can write

$$I_{abc} = \left(\frac{3}{Z_{\Delta}} + \frac{1}{Z_Y} \right) V_{abc} - \frac{1}{Z_{\Delta}} \begin{bmatrix} 1 & 1 & 1 \\ 1 & 1 & 1 \\ 1 & 1 & 1 \end{bmatrix} V_{abc} - \frac{V_n}{Z_Y} \begin{bmatrix} 1 \\ 1 \\ 1 \end{bmatrix}$$

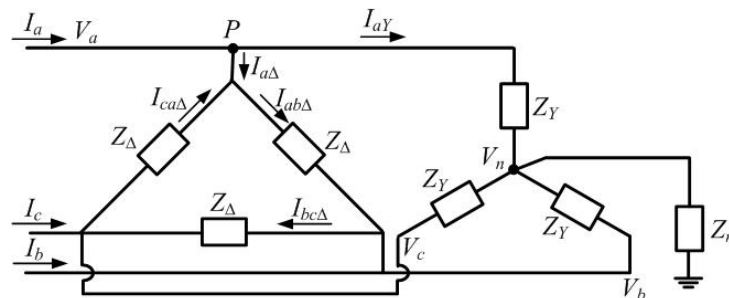

Fig. 7.5 Parallel connection of balanced Δ and Y-connected loads.

Pre-multiplying both sides of the above expression by the transformation matrix C we get

$$I_{a012} = \left(\frac{3}{Z_{\Delta}} + \frac{1}{Z_Y} \right) V_{a012} - \frac{1}{Z_{\Delta}} C \begin{bmatrix} 1 & 1 & 1 \\ 1 & 1 & 1 \\ 1 & 1 & 1 \end{bmatrix} C^{-1} V_{a012} - \frac{V_n}{Z_Y} C \begin{bmatrix} 1 \\ 1 \\ 1 \end{bmatrix}$$

Now since

$$C \begin{bmatrix} 1 & 1 & 1 \\ 1 & 1 & 1 \\ 1 & 1 & 1 \end{bmatrix} C^{-1} = \begin{bmatrix} 3 & 0 & 0 \\ 0 & 0 & 0 \\ 0 & 0 & 0 \end{bmatrix}$$

we get

$$I_{a012} = \left(\frac{3}{Z_{\Delta}} + \frac{1}{Z_Y} \right) V_{a012} - \frac{3}{Z_{\Delta}} V_{a0} - \frac{V_n}{Z_Y} \begin{bmatrix} 1 \\ 0 \\ 0 \end{bmatrix}$$

Separating the three components, we can write from the above equation

$$\begin{aligned} I_{a1} &= \left(\frac{3}{Z_{\Delta}} + \frac{1}{Z_Y} \right) V_{a1} \\ I_{a2} &= \left(\frac{3}{Z_{\Delta}} + \frac{1}{Z_Y} \right) V_{a2} \\ I_{a0} &= \frac{1}{Z_Y} V_{a0} - \frac{1}{Z_Y} V_n \end{aligned}$$

Suppose now if we convert the Δ -connected load into an equivalent Y, then the composite load will be a parallel combination of two Y-connected circuits – one with an impedance of Z_Y and the other with an impedance of $Z_{\Delta}/3$. Therefore the positive and the negative sequence impedances are given by the parallel combination of these two impedances. The positive and negative sequence impedance is then given by

$$\frac{Z_Y Z_{\Delta}/3}{Z_Y + Z_{\Delta}/3}$$

Now refer to Fig. 7.5. The voltage V_n is given by

$$V_n = Z_n(I_{aY} + I_{bY} + I_{cY}) = 3Z_n I_{aY0}$$

From Fig. 7.5 we can also write $I_a = I_{a\Delta} + I_{aY}$. Therefore

$$\begin{aligned} I_a + I_b + I_c &= I_{a\Delta} + I_{b\Delta} + I_{c\Delta} + I_{aY} + I_{bY} + I_{cY} \\ &= I_{ab\Delta} - I_{ca\Delta} + I_{bc\Delta} - I_{ab\Delta} + I_{ca\Delta} - I_{bc\Delta} + I_{aY} + I_{bY} + I_{cY} \end{aligned}$$

This implies that $I_{a0} = I_{aY0}$ and hence $V_n = 3Z_n I_{a0}$. We can then rewrite the zero sequence current expression as

$$I_{a0} = \frac{V_{a0}}{Z_Y + 3Z_n}$$

It can be seen that the Z_{Δ} term is absent from the zero sequence impedance.

△△△

7.3 SEQUENCE CIRCUITS FOR SYNCHRONOUS GENERATOR

The three-phase equivalent circuit of a synchronous generator is shown in Fig. 1.16. This is redrawn in Fig. 7.6 with the neutral point grounded through a reactor with impedance Z_n . The neutral current is then given by

$$I_n = I_a + I_b + I_c \quad (7.32)$$

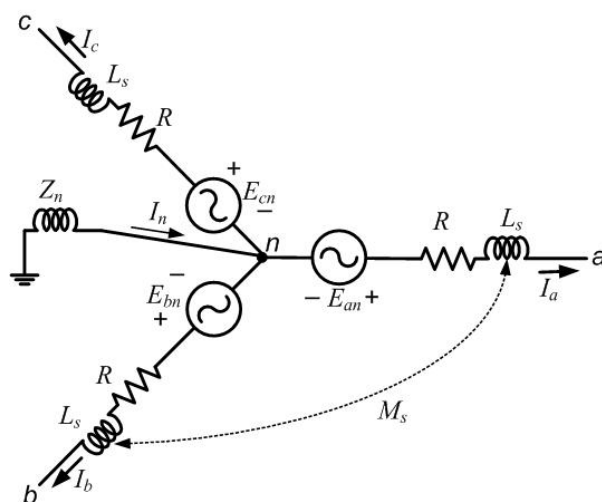

Fig. 7.6 Equivalent circuit of a synchronous generator with grounded neutral.

The derivation of Section 1.3 assumes balanced operation which implies $I_a + I_b + I_c = 0$. As per (7.32) this assumption is not valid any more. Therefore with respect to this figure we can write for phase-a voltage as

$$\begin{aligned} V_{an} &= -(R + j\omega L_s)I_a + j\omega M_s(I_b + I_c) + E_{an} \\ &= -(R + j\omega L_s + j\omega M_s)I_a + j\omega M_s(I_a + I_b + I_c) + E_{an} \end{aligned} \quad (7.33)$$

Similar expressions can also be written for the other two phases. We therefore have

$$\begin{bmatrix} V_{an} \\ V_{bn} \\ V_{cn} \end{bmatrix} = -[R + j\omega(L_s + M_s)] \begin{bmatrix} I_a \\ I_b \\ I_c \end{bmatrix} + j\omega M_s \begin{bmatrix} 1 & 1 & 1 \\ 1 & 1 & 1 \\ 1 & 1 & 1 \end{bmatrix} \begin{bmatrix} I_a \\ I_b \\ I_c \end{bmatrix} + \begin{bmatrix} E_{an} \\ E_{bn} \\ E_{cn} \end{bmatrix} \quad (7.34)$$

Pre-multiplying both sides of (7.34) by the transformation matrix C we get

$$\begin{bmatrix} V_{an0} \\ V_{an1} \\ V_{an2} \end{bmatrix} = -[R + j\omega(L_s + M_s)] \begin{bmatrix} I_{a0} \\ I_{a1} \\ I_{a2} \end{bmatrix} + j\omega M_s C \begin{bmatrix} 1 & 1 & 1 \\ 1 & 1 & 1 \\ 1 & 1 & 1 \end{bmatrix} C^{-1} \begin{bmatrix} I_{a0} \\ I_{a1} \\ I_{a2} \end{bmatrix} + \begin{bmatrix} E_{an0} \\ E_{an1} \\ E_{an2} \end{bmatrix} \quad (7.35)$$

Since the synchronous generator is operated to supply only balanced voltages we can assume that $E_{an0} = E_{an2} = 0$ and $E_{an1} = E_{an}$. We can therefore modify (7.35) as

$$\begin{bmatrix} V_{an0} \\ V_{an1} \\ V_{an2} \end{bmatrix} = -[R + j\omega(L_s + M_s)] \begin{bmatrix} I_{a0} \\ I_{a1} \\ I_{a2} \end{bmatrix} + j\omega M_s \begin{bmatrix} 3 & 0 & 0 \\ 0 & 0 & 0 \\ 0 & 0 & 0 \end{bmatrix} \begin{bmatrix} I_{a0} \\ I_{a1} \\ I_{a2} \end{bmatrix} + \begin{bmatrix} 0 \\ E_{an} \\ 0 \end{bmatrix} \quad (7.36)$$

We can separate the terms of (7.36) as

$$V_{an0} = -[R + j\omega(L_s - 2M_s)]I_{a0} = -Z_{g0}I_{a0} \quad (7.37)$$

$$V_{an1} = -[R + j\omega(L_s + M_s)]I_{a1} + E_{an} = E_{an} - Z_1 I_{a1} \quad (7.38)$$

$$V_{an2} = -[R + j\omega(L_s + M_s)]I_{a2} = -Z_2 I_{a2} \quad (7.39)$$

Furthermore we have seen for a Y-connected load that $V_{a1} = V_{an1}$, $V_{a2} = V_{an2}$ since the neutral current does not affect these voltages. However $V_{a0} = V_{an0} + V_n$. Also we know that $V_n = -3Z_n I_{a0}$. We can therefore rewrite (7.37) as

$$V_{a0} = -(Z_{g0} + 3Z_n)I_{a0} = -Z_0 I_{a0} \quad (7.40)$$

The sequence diagrams for a synchronous generator are shown in Fig. 7.7.

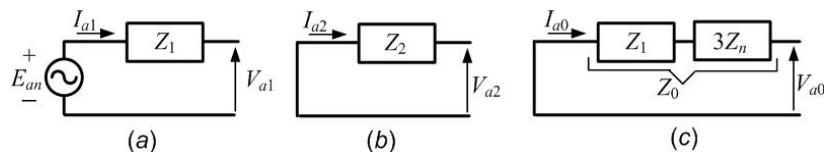

Fig. 7.7 Sequence circuits of synchronous generator: (a) positive, (b) negative and (c) zero sequence.

7.4 SEQUENCE CIRCUITS FOR SYMMETRICAL TRANSMISSION LINE

The schematic diagram of a transmission line is shown in Fig. 7.8. In this diagram the self impedance of the three phases are denoted by Z_{aa} , Z_{bb} and Z_{cc} while that of the neutral wire is denoted by Z_{nn} . Let us assume that the self impedances of the conductors to be the same, i.e.,

$$Z_{aa} = Z_{bb} = Z_{cc}$$

Since the transmission line is assumed to be symmetric, we further assume that the mutual inductances between the conductors are the same and so are the mutual inductances between the conductors and the neutral, i.e.,

$$\begin{aligned} Z_{ab} &= Z_{bc} = Z_{ca} \\ Z_{an} &= Z_{bn} = Z_{cn} \end{aligned}$$

The directions of the currents flowing through the lines are indicated in Fig. 7.8 and the voltages between the different conductors are as indicated.

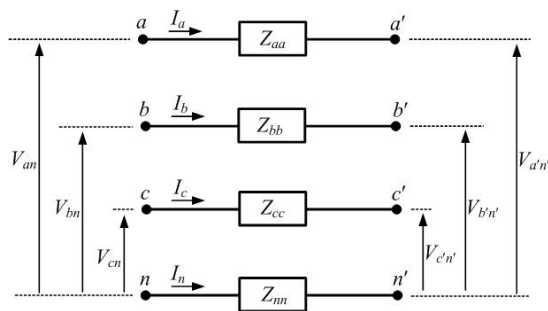

Fig. 7.8 Lumped parameter representation of a symmetrical transmission line.

Applying Kirchoff's voltage law we get

$$V_{an} = V_{aa'} + V_{a'n'} + V_{n'n} = V_{aa'} + V_{a'n'} - V_{nn'} \quad (7.41)$$

Again

$$V_{aa'} = Z_{aa}I_a + Z_{ab}(I_b + I_c) + Z_{an}I_n \quad (7.42)$$

$$V_{nn'} = Z_{nn}I_n + Z_{an}(I_a + I_b + I_c) \quad (7.43)$$

Substituting (7.42) and (7.43) in (7.41) we get

$$V_{an} - V_{a'n'} = (Z_{aa} - Z_{an})I_a + (Z_{ab} - Z_{an})(I_b + I_c) + (Z_{an} - Z_{nn})I_n \quad (7.44)$$

Since the neutral provides a return path for the currents I_a , I_b and I_c , we can write

$$I_n = -(I_a + I_b + I_c) \quad (7.45)$$

Therefore substituting (7.45) in (7.44) we get the following equation for phase-a of the circuit

$$V_{an} - V_{a'n'} = (Z_{aa} + Z_{nn} - 2Z_{an})I_a + (Z_{ab} + Z_{nn} - 2Z_{an})(I_b + I_c) \quad (7.46)$$

Denoting

$$Z_s = Z_{aa} + Z_{nn} - 2Z_{an} \quad \text{and} \quad Z_m = Z_{ab} + Z_{nn} - 2Z_{an}$$

(7.46) can be rewritten as

$$V_{an} - V_{a'n'} = Z_s I_a + Z_m (I_b + I_c) \quad (7.47)$$

Since (7.47) does not explicitly include the neutral conductor we can define the voltage drop across the phase-a conductor as

$$V_{aa'} = V_{an} - V_{a'n'} \quad (7.48)$$

Combining (7.47) and (7.48) we get

$$V_{aa'} = Z_s I_a + Z_m (I_b + I_c) \quad (7.49)$$

Similar expression can also be written for the other two phases. We therefore get

$$\begin{bmatrix} V_{aa'} \\ V_{bb'} \\ V_{cc'} \end{bmatrix} = \begin{bmatrix} Z_s & Z_m & Z_m \\ Z_m & Z_s & Z_m \\ Z_m & Z_m & Z_s \end{bmatrix} \begin{bmatrix} I_a \\ I_b \\ I_c \end{bmatrix} \quad (7.50)$$

Pre-multiplying both sides of (7.50) by the transformation matrix C we get

$$V_{aa'012} = C \begin{bmatrix} Z_s & Z_m & Z_m \\ Z_m & Z_s & Z_m \\ Z_m & Z_m & Z_s \end{bmatrix} C^{-1} I_{a012} \quad (7.51)$$

Now

$$\begin{aligned} \begin{bmatrix} Z_s & Z_m & Z_m \\ Z_m & Z_s & Z_m \\ Z_m & Z_m & Z_s \end{bmatrix} C^{-1} &= \begin{bmatrix} Z_s & Z_m & Z_m \\ Z_m & Z_s & Z_m \\ Z_m & Z_m & Z_s \end{bmatrix} \begin{bmatrix} 1 & 1 & 1 \\ 1 & a^2 & a \\ 1 & a & a^2 \end{bmatrix} \\ &= \begin{bmatrix} Z_s + 2Z_m & Z_s - Z_m & Z_s - Z_m \\ Z_s + 2Z_m & a^2 Z_s + (1+a)Z_m & aZ_s + (1+a^2)Z_m \\ Z_s + 2Z_m & aZ_s + (1+a^2)Z_m & a^2 Z_s + (1+a)Z_m \end{bmatrix} \end{aligned}$$

Hence

$$\begin{aligned} C \begin{bmatrix} Z_s & Z_m & Z_m \\ Z_m & Z_s & Z_m \\ Z_m & Z_m & Z_s \end{bmatrix} C^{-1} &= \frac{1}{3} \begin{bmatrix} 1 & 1 & 1 \\ 1 & a & a^2 \\ 1 & a^2 & a \end{bmatrix} \begin{bmatrix} Z_s + 2Z_m & Z_s - Z_m & Z_s - Z_m \\ Z_s + 2Z_m & a^2 Z_s + (1+a)Z_m & aZ_s + (1+a^2)Z_m \\ Z_s + 2Z_m & aZ_s + (1+a^2)Z_m & a^2 Z_s + (1+a)Z_m \end{bmatrix} \\ &= \frac{1}{3} \begin{bmatrix} 3Z_s + 6Z_m & 0 & 0 \\ 0 & 3Z_s - 3Z_m & 0 \\ 0 & 0 & 3Z_s - 3Z_m \end{bmatrix} \end{aligned}$$

Therefore from (7.51) we get

$$\begin{bmatrix} V_{aa'0} \\ V_{aa'1} \\ V_{aa'2} \end{bmatrix} = \begin{bmatrix} Z_s + 2Z_m & & \\ & Z_s - Z_m & \\ & & Z_s - Z_m \end{bmatrix} \begin{bmatrix} I_{a0} \\ I_{a1} \\ I_{a2} \end{bmatrix} \quad (7.52)$$

The positive, negative and zero sequence equivalent circuits of the transmission line are shown in Fig. 7.9 where the sequence impedances are

$$\begin{aligned} Z_1 &= Z_2 = Z_s - Z_m = Z_{aa} - Z_{ab} \\ Z_0 &= Z_s + 2Z_m = Z_{aa} + 2Z_{ab} + 3Z_{nn} - 6Z_{an} \end{aligned}$$

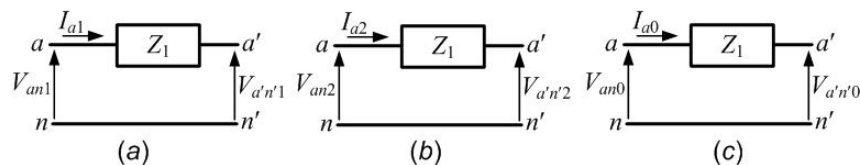

Fig. 7.9 Sequence circuits of symmetrical transmission line: (a) positive, (b) negative and (c) zero sequence.

7.5 SEQUENCE CIRCUITS FOR TRANSFORMERS

In this section we shall discuss the sequence circuits of transformers. As we have seen earlier that the sequence circuits are different for Y- and Δ -connected loads, the sequence circuits are also different for Y and Δ connected transformers. We shall therefore treat different transformer connections separately.

7.5.1 Y-Y Connected Transformer

Fig. 7.10 shows the schematic diagram of a Y-Y connected transformer in which both the neutrals are grounded. The primary and secondary side quantities are denoted by subscripts in uppercase letters and lowercase letters respectively. The turns ratio of the transformer is given by $\alpha = N_1:N_2$.

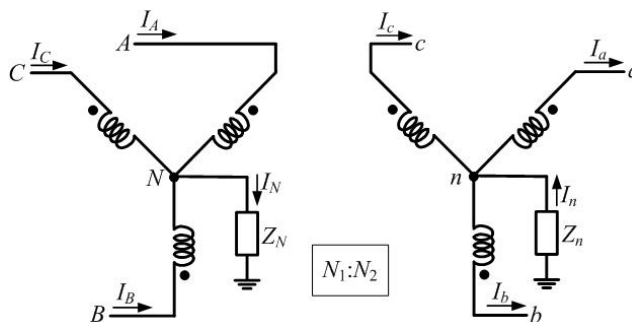

Fig. 7.10 Schematic diagram of a grounded neutral Y-Y connected transformer.

The voltage of phase-a of the primary side is

$$V_A = V_{AN} + V_N = V_{AN} + 3Z_N I_{A0}$$

Expanding V_A and V_{AN} in terms of their positive, negative and zero sequence components, the above equation can be rewritten as

$$V_{A0} + V_{A1} + V_{A2} = V_{AN0} + V_{AN1} + V_{AN2} + 3Z_N I_{A0} \quad (7.53)$$

Noting that the direction of the neutral current I_n is opposite to that of I_N , we can write an equation similar to that of (7.53) for the secondary side as

$$V_{a0} + V_{a1} + V_{a2} = V_{an0} + V_{an1} + V_{an2} - 3Z_n I_{a0} \quad (7.54)$$

Now since the turns ratio of the transformer is $\alpha = N_1:N_2$ we can write

$$\begin{aligned} \alpha &= \frac{N_1}{N_2} = \frac{V_{AN}}{V_{an}} \Rightarrow V_{an} = \frac{V_{AN}}{\alpha} \\ N_1 I_A &= N_2 I_a \Rightarrow I_a = \alpha I_A \end{aligned}$$

Substituting in (7.54) we get

$$V_{a0} + V_{a1} + V_{a2} = \frac{1}{\alpha} (V_{AN0} + V_{AN1} + V_{AN2}) - 3Z_n \alpha I_{A0}$$

Multiplying both sides of the above equation by α results in

$$\alpha(V_{a0} + V_{a1} + V_{a2}) = V_{AN0} + V_{AN1} + V_{AN2} - 3Z_n \alpha^2 I_{A0} \quad (7.55)$$

Finally combining (7.53) with (7.55) we get

$$\alpha(V_{a0} + V_{a1} + V_{a2}) = V_{A0} + V_{A1} + V_{A2} - 3(Z_N + Z_n \alpha^2)I_{A0} \quad (7.56)$$

Separating out the positive, negative and zero sequence components we can write

$$\alpha V_{a1} = \frac{N_1}{N_2} V_{A1} = V_{A1} \quad (7.57)$$

$$\alpha V_{a2} = \frac{N_1}{N_2} V_{A2} = V_{A2} \quad (7.58)$$

$$\alpha V_{a0} = \frac{N_1}{N_2} V_{A0} = V_{A0} - 3[Z_N + (N_1/N_2)^2 Z_n]I_{A0} \quad (7.59)$$

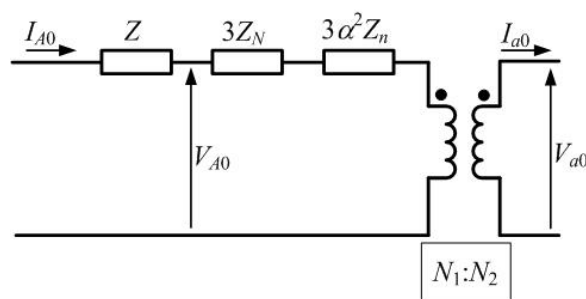

Fig. 7.11 Zero sequence equivalent circuit of grounded neutral Y-Y connected transformer.

From (7.57) and (7.58) we see that the positive and negative sequence relations are the same as that we have used for representing transformer circuits given in Fig. 1.18. Hence the positive and negative sequence impedances are the same as the transformer leakage impedance Z . The zero sequence equivalent circuit is shown in Fig. 7.11. The total zero sequence impedance is given by

$$Z_0 = Z + 3Z_N + 3(N_1/N_2)^2 Z_n \quad (7.60)$$

The zero sequence diagram of the grounded neutral Y-Y connected transformer is shown in Fig. 7.12 (a) in which the impedance Z_0 is as given in (7.60). If both the neutrals are solidly grounded, i.e., $Z_n = Z_N = 0$, then Z_0 is equal to Z . The single line diagram is still the same as that shown in Fig. 7.12 (a). If however one of the two neutrals or both neutrals are ungrounded, then we have either $Z_n = \infty$ or $Z_N = \infty$ or both. The zero sequence diagram is then as shown in Fig. 7.12 (b) where the value of Z_0 will depend on which neutral is kept ungrounded.

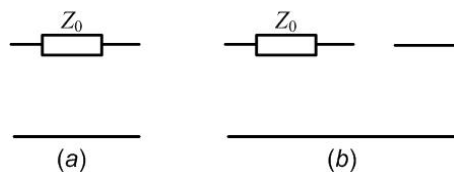

Fig. 7.12 Zero sequence diagram of (a) grounded neutral and (b) ungrounded neutral Y-Y connected transformer.

7.5.2 Δ - Δ Connected Transformer

The schematic diagram of a Δ - Δ connected transformer is shown in Fig. 7.13. Now we have

$$\begin{aligned} V_{AB} &= V_A - V_B \\ &= V_{A0} + V_{A1} + V_{A2} - V_{B0} - V_{B1} - V_{B2} = V_{AB1} + V_{AB2} \end{aligned} \quad (7.61)$$

Again

$$V_{AB} = \frac{N_1}{N_2} V_{ab} = \alpha V_{ab}$$

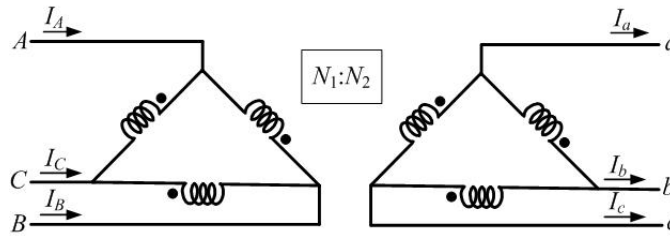

Fig. 7.13 Schematic diagram of a Δ - Δ connected transformer.

Therefore from (7.61) we get

$$V_{AB} = V_{AB1} + V_{AB2} = \alpha(V_{ab1} + V_{ab2}) \quad (7.62)$$

The sequence components of the line-to-line voltage V_{AB} can be written in terms of the sequence components of the line-to-neutral voltage as

$$V_{AB1} = \sqrt{3}V_{AN1} \angle 30^\circ \quad (7.63)$$

$$V_{AB2} = \sqrt{3}V_{AN2} \angle -30^\circ \quad (7.64)$$

Therefore combining (7.62)-(7.64) we get

$$\sqrt{3}V_{AN1} \angle 30^\circ + \sqrt{3}V_{AN2} \angle -30^\circ = \alpha(\sqrt{3}V_{an1} \angle 30^\circ + \sqrt{3}V_{an2} \angle -30^\circ) \quad (7.65)$$

Hence we get

$$V_{AN1} = \alpha V_{an1} \quad \text{and} \quad V_{AN2} = \alpha V_{an2} \quad (7.66)$$

Thus the positive and negative sequence equivalent circuits are represented by a series impedance that is equal to the leakage impedance of the transformer. Since the Δ -connected winding does not provide any path for the zero sequence current to flow we have

$$I_{A0} = I_{a0} = 0$$

However the zero sequence current can sometimes circulate within the Δ windings. We can then draw the zero sequence equivalent circuit as shown in Fig. 7.14.

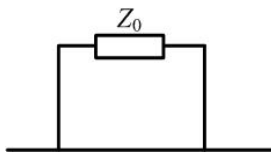

Fig. 7.14 Zero sequence diagram of Δ - Δ connected transformer.

7.5.3 Y- Δ Connected Transformer

The schematic diagram of a Y- Δ connected transformer is shown in Fig. 7.15. It is assumed that the Y-connected side is grounded with the impedance Z_N . Even though the zero sequence current in the primary Y-connected side has a path to the ground, the zero sequence current flowing in the Δ -connected secondary winding has no path to flow in the line. Hence we have $I_{a0} = 0$. However the circulating zero sequence current in the Δ winding magnetically balances the zero sequence current of the primary winding.

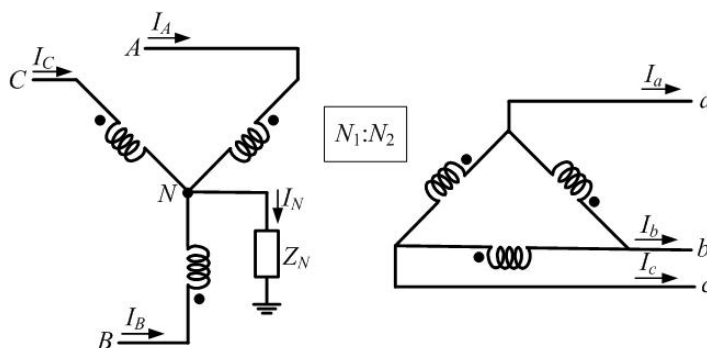

Fig. 7.15 Schematic diagram of a Y- Δ connected transformer.

The voltage in phase-a of both sides of the transformer is related by

$$V_{AN} = \frac{N_1}{N_2} V_{ab} = \alpha V_{ab}$$

Also we know that

$$V_A = V_{AN} + V_N$$

We therefore have

$$\begin{aligned} V_{A0} + V_{A1} + V_{A2} &= V_{AN0} + V_{AN1} + V_{AN2} + 3Z_N I_{A0} \\ &= \alpha(V_{ab0} + V_{ab1} + V_{ab2}) + 3Z_N I_{A0} \end{aligned} \quad (7.67)$$

Separating zero, positive and negative sequence components we can write

$$V_{A0} - 3Z_N I_{A0} = \alpha V_{ab0} = 0 \quad (7.68)$$

$$V_{A1} = \alpha V_{ab1} = \sqrt{3}\alpha V_{a1} \angle 30^\circ \quad (7.69)$$

$$V_{A2} = \alpha V_{ab2} = \sqrt{3}\alpha V_{a2} \angle -30^\circ \quad (7.70)$$

The positive sequence equivalent circuit is shown in Fig. 7.16 (a). The negative sequence circuit is the same as that of the positive sequence circuit except for the phase shift in the induced emf. This is shown in Fig. 7.16 (b). The zero sequence equivalent circuit is shown in Fig. 7.16 (c) where $Z_0 = Z + 3Z_N$. Note that the primary and the secondary sides are not connected and hence there is an open circuit between them. However since the zero sequence current flows through primary windings, a return path is provided through the ground. If however, the neutral in the primary side is not grounded, i.e., $Z_N = \infty$, then the zero sequence current cannot flow in the primary side as well. The sequence diagram is then as shown in Fig. 7.16 (d) where $Z_0 = Z$.

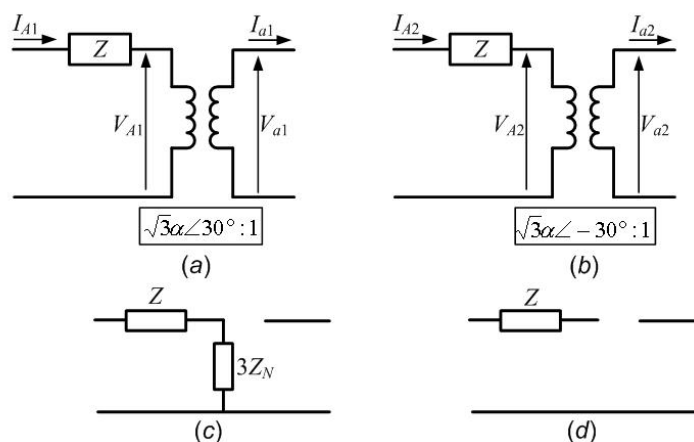

Fig. 7.16 Sequence diagram of a Y- Δ connected transformer: (a) positive sequence, (b) negative sequence, (c) zero sequence with grounded Y-connection and (d) zero sequence with ungrounded Y-connection.

7.6 SEQUENCE NETWORKS

The sequence circuits developed in the previous sections are combined to form the sequence networks. The sequence networks for the positive, negative and zero sequences are formed separately by combining the sequence circuits of all the individual elements. Certain assumptions are made while forming the sequence networks. These are listed below.

1. Apart from synchronous machines, the network is made of static elements.
2. The voltage drop caused by the current in a particular sequence depends only on the impedance of that part of the network.
3. The positive and negative sequence impedances are equal for all static circuit components, while the zero sequence component need not be the same as them. Furthermore subtransient positive and negative sequence impedances of a synchronous machine are equal.
4. Voltage sources are connected to the positive sequence circuits of the rotating machines.
5. No positive or negative sequence current flows between neutral and ground.

Example 7.5: Let us consider the network shown in Fig 7.17 which is essentially the same as that discussed in Example 1.2. The values of the various reactances are not important here and hence are not given in this figure. However various points of the circuit are denoted by the letters A to G . This has been done to identify the impedances of various circuit elements. For example, the leakage reactance of the transformer T_1 is placed between the points A and B and that of transformer T_2 is placed between D and E .

The positive sequence network is shown in Fig. 7.18. This is essentially same as that shown in Fig. 1.24. The negative sequence diagram, shown in Fig. 7.19, is almost identical to the positive sequence diagram except that the voltage sources are absent in this circuit. The zero sequence network is shown in Fig. 7.20. The neutral point of generator G_1 is grounded. Hence a path from point A to the ground is provided through the zero sequence reactance of the generator. The primary side of the transformer T_1 is Δ -connected and hence there is discontinuity in the circuit after point A . Similar connections are also made for generator G_2 and transformer T_2 . The transmission line impedances are placed between the points B – C , C – D and C – F . The secondary side of transformer T_3 is ungrounded and hence there is a break in the circuit after the point F . However the primary side of T_3 is grounded and so is the neutral point of generator G_3 . Hence the zero sequence components of these two apparatus are connected to the ground.

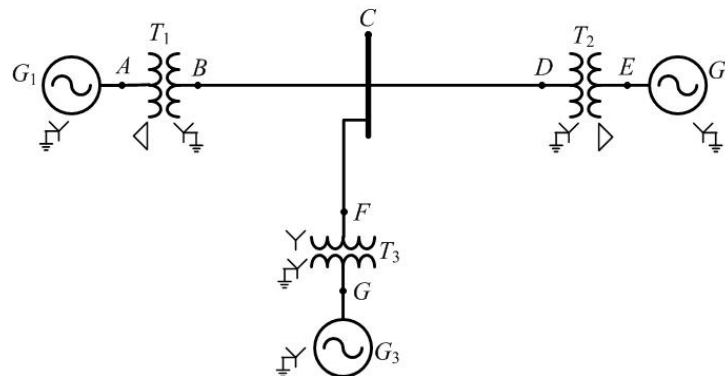

Fig. 7.17 Single-line diagram of a 3-machine power system.

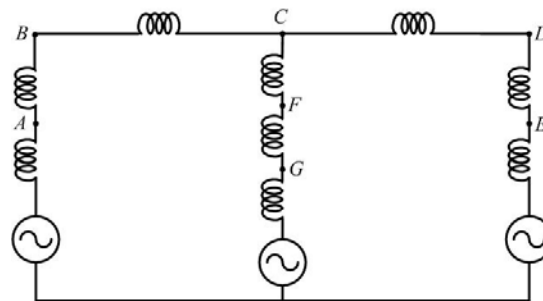

Fig. 7.18 Positive sequence network of the power system of Fig. 7.17.

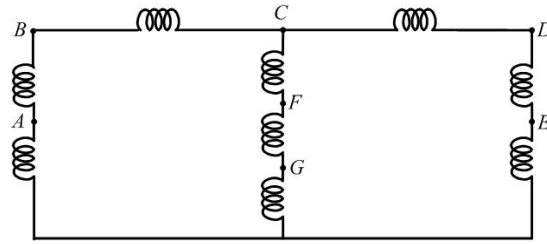

Fig. 7.19 Negative sequence network of the power system of Fig. 7.17.

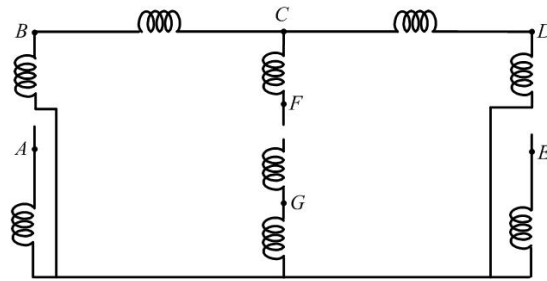

Fig. 7.20 Zero sequence network of the power system of Fig. 7.17.

△△△